

DE-GLAZING

- 1.) If there is any PVC cement covering the joints where external glazing bead strips meet, cut through the cement with a utility knife.
- 2.) Using a small 2 X 4 block or similar instrument, tap along each glazing bead's fin until it comes free of its placement groove.

**Example:
Top Bead**

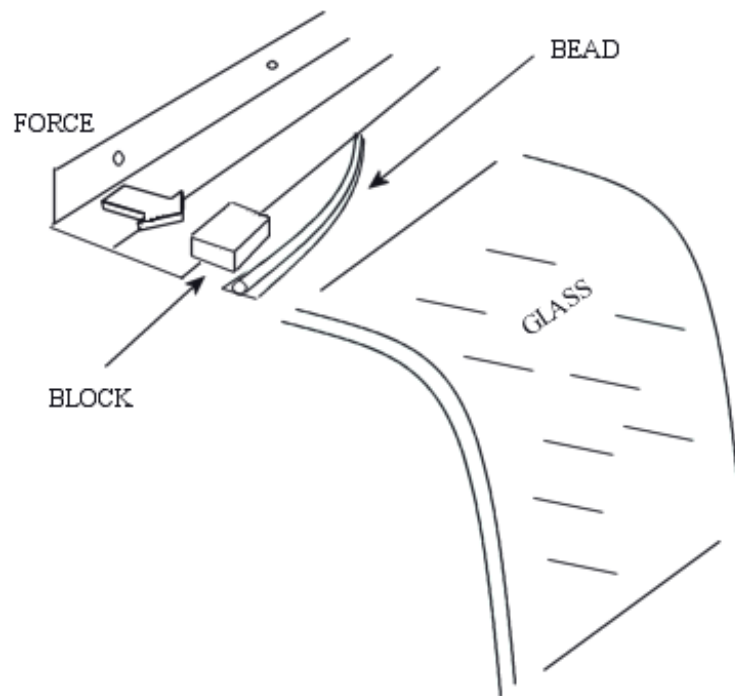

- 3.) Either a putty or utility knife will be useful in separating the glass from the tape from the inside. Try to avoid damaging the frame as you cut the glass free along all four interior edges.
- 4.) If bent glass cannot be pushed out at this stage, find a long sharp instrument to work the glass free from the caulk from the outside. Since the four bead strips have been removed (Step 2), the caulk that the glass was set in should be visible. Cut away at this caulk and continue to work at the glazing tape seal on the inside. Eventually, the bond to the glass will be loosened sufficiently so that the glass can be pushed out.

GLASS FITTING

Once all four of the window frame's glazing surfaces have been taped, the bent glass unit should be set into the opening before any caulk has been applied to check for any necessary adjustments.

Ideally, the inner pane of the glass should completely cover the glazing tape, but this isn't possible due to the width of the tape applied to the lower mullion. Instead, two simple things should be kept in mind: First, align the glass so that the left and the right vertical gaps are approximately equal ($1/8 - 3/16$ "). Secondly, where you are fitting glass, not actually glazing, you should not be able to see any of the glazing tape's red backing when you inspect the gap around the glass. If you can see the red tape adjustments are necessary. Left/right adjustments shouldn't be necessary. Up/down adjustments, however, may be required. This is why there are different sized shims included with your bent IG. Use whatever combination of shims that are necessary to raise the top edge of the inner pane of glass beyond the glazing tape.

Once the glass has been fitted, make some light pencil marks on the top and bottom mullions as permanent guidelines for when you actually glaze the window.

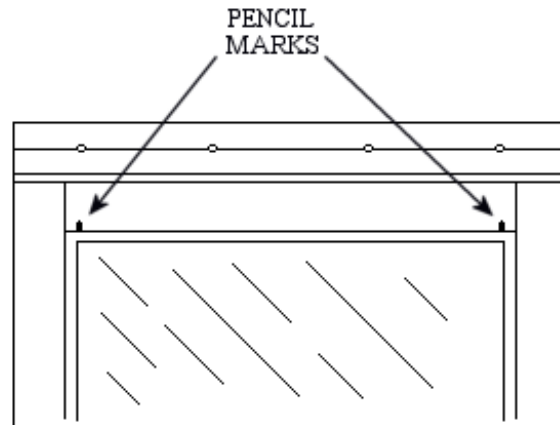

GLASS INSTALLATION INSTRUCTIONS

-CURVED-

TAPING

~ Once the old glass is removed and the glazing surface is stripped clean of tape, lightly re-apply an alcohol-water solution to the four glazing edges.

~ Now apply the new tape (note that there are two different widths, $\frac{3}{4}$ " and $\frac{3}{8}$ "). First, place a strip of $\frac{3}{4}$ " tape along the lower glazing edge.

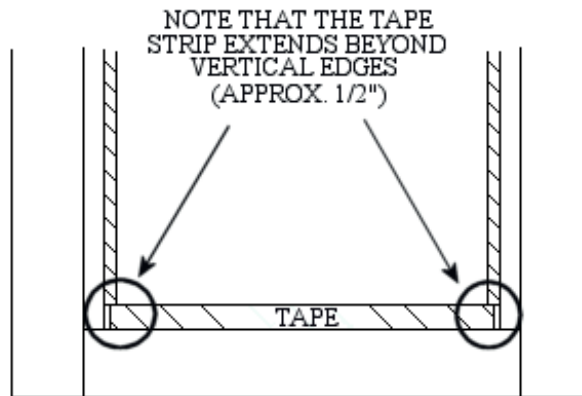

~ Apply $\frac{3}{8}$ " tape to the remaining three surfaces. Tape the horizontal edges, then verticals.

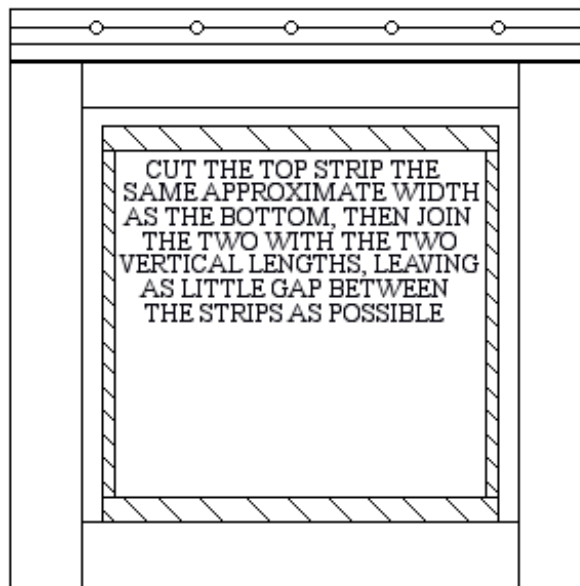

GLAZING

~ Set the glass in. This is most easily performed using two people. Rest the bottom edge of the glass on the shims without touching the tape while a second person attempts to center the glass from the left to right. Try to get a gap of approximately $\frac{1}{8}$ " – $\frac{3}{16}$ " between the glass and the frame on both sides. Try to keep this gap the same at the top when finishing.

- ~ Once centered, stick the lower edge of the glass against the tape one corner at a time. Then, using one person per side, you will slowly move the glass forward with your body while resting this forward motion gently by pulling the top edge backwards with your fingers.
- ~ This is not as hard as it may sound.
- ~ The idea is to stretch the curve of the glass over the curve of the frame from the bottom up.
- ~ The upper 1/3 of the glass should be the last part of the glass to slap down against the tape.
- ~ Once in place, run a shim (or similar blunt object) around the gap between the glass and the frame to displace the clear caulk towards the glass and create a seal.
- ~ Replace the glazing bead.

- ~ Using a utility knife, cut two gaps in the bottom tape strip for the shims to be recessed in.

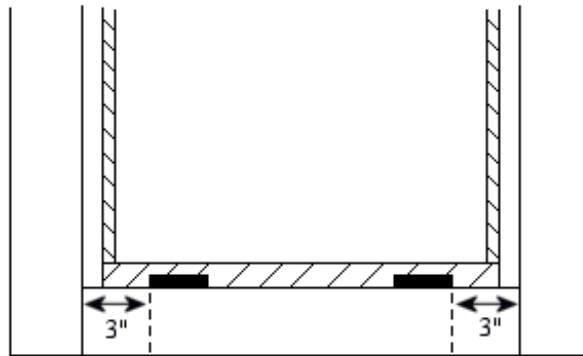

- ~ Lightly fill these gaps with clear caulk then insert shims. Remove the bottom strips red backing. Run 1/4" bead of clear caulk across the bottom of the bottom strip.

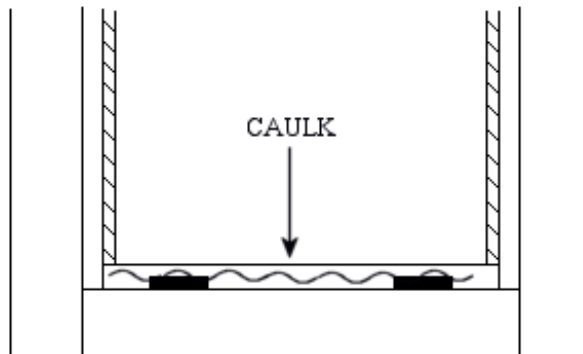

~ Fill the channel between $\frac{3}{8}$ " tape and frame on the remaining three sides with the same approximately $\frac{1}{4}$ " bead of caulk. Once this is done, remove all remaining backing from the tape.

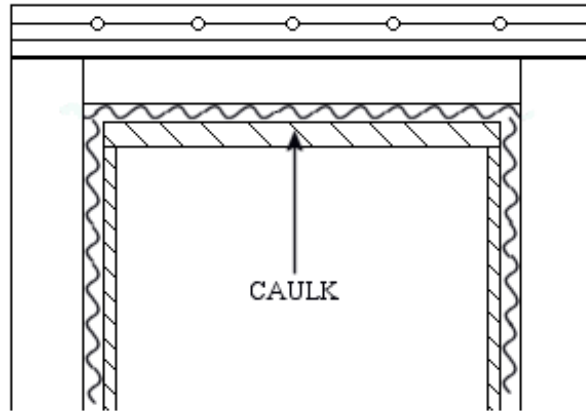

SIDELIGHT REPLACEMENT INSTRUCTIONS

-DE-GLAZING-

- ~ Using a punch or a nail, drive the sash pins up and out of the hinges to separate the sash from the frame.
- ~ Open the sash and slide it forward off of the operator track.

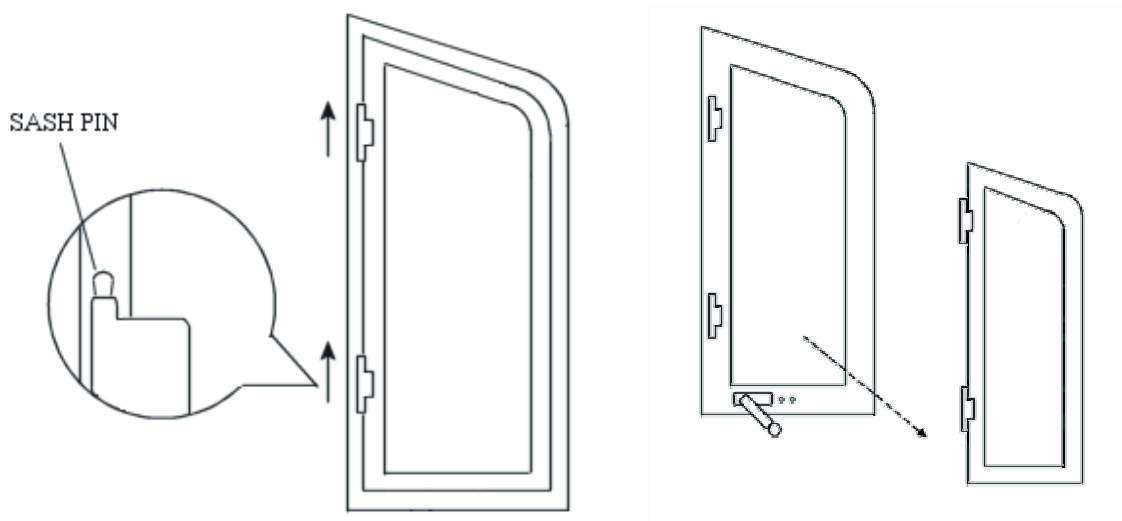

- ~ Lay the sash flat on a table (hinges side up) and, using a utility knife or similar tool, wedge the blade between the glass and the vinyl to separate the glass from the glazing tape.

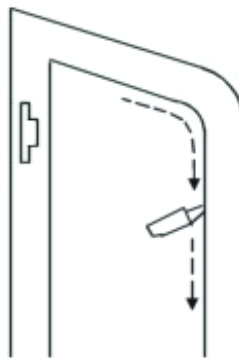

- ~ Turn the sash over (glazing bead side up) and use a knife to cut through the window cement at all three corners.

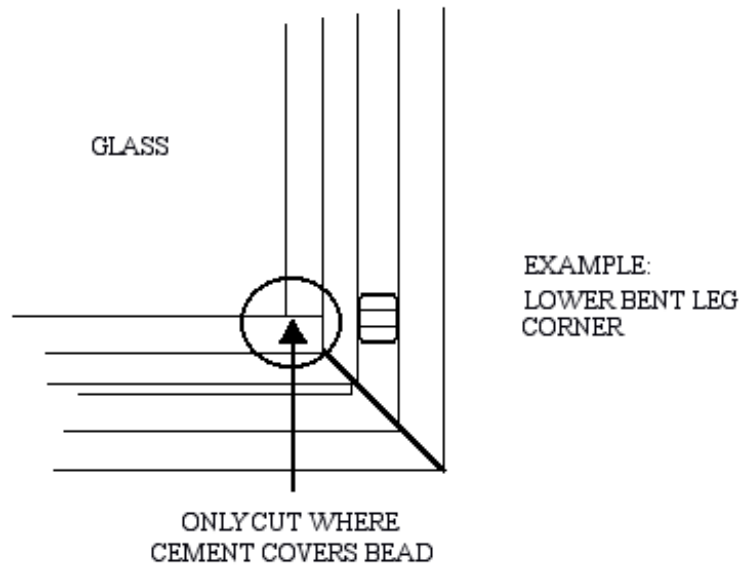

~ Remove the glazing bead. Use a flat head screwdriver or sharp chisel and start in the lower bent leg corner shown in figures 4 and 5. Wedge the blade tip between the frame and the glazing bead and strike the screwdriver softly with a mallet directing the blows away from the frame, not downward. Be very careful to avoid damaging the sash frame when removing the bead. Use fine grit sandpaper to buff out any damage to the sash that that may occur in the process.

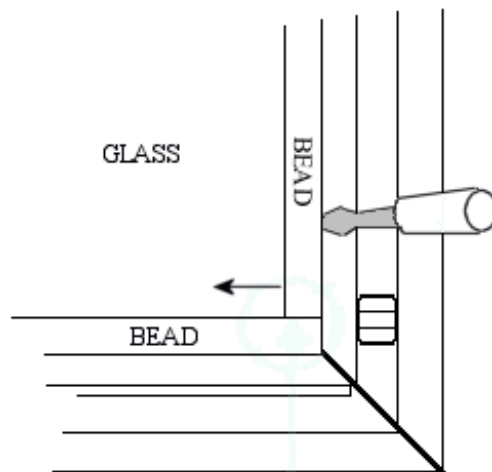

~ After removing the bent leg bead, remove the long straight leg starting at the top of the sash. The short bottom leg can then be removed, starting at either end. KEEP ALL BLOWS AS CLOSE TO THE CORNERS AS POSSIBLE.

- ~ Once the 3 pieces of bead are removed, the glazing tape will be visible. It will help here to spray 409 on the tape all the way around the glass.
- ~ Turn the sash over and press the glass downwards at the corners to loosen it. Continue to cut at the tape with a knife as needed. Once the sidelight corners are free, work pressure all the way around until the glass can be easily removed.
- ~ Using 409 and a chisel, scrape the old glazing tape off the sash.
- ~ Use a 50/50 alcohol/water solution to lightly wipe down the surface where the new glazing tape will be placed.

-GLAZING-

- ~ Trying to start and end the new tape as close as possible to the walls of the sash frame, lay the bottom short leg piece down first, cutting it when it reaches the long back leg wall.

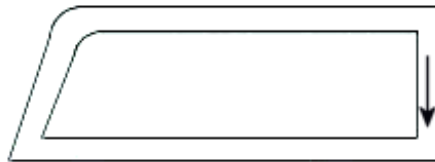

- ~ The long back leg piece is next. Cut it at an angle when you reach the top of the sash. Do the bent piece last, working from bottom to top, snipping it one-half way through with wire-snippers as you lay it around the curve. The table should look like figure 6.

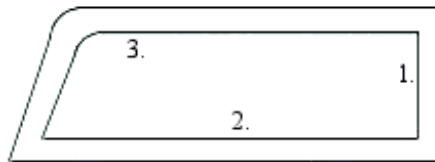

- ~ Place two short 2 X 4 blocks in the center of the sash and set the new sidelight on them. Leave the blue backing on the tape and raise the sash upwards to check the fit of the glass. Remove tape backing and repeat the procedure when you are ready to glaze. See figure 7.

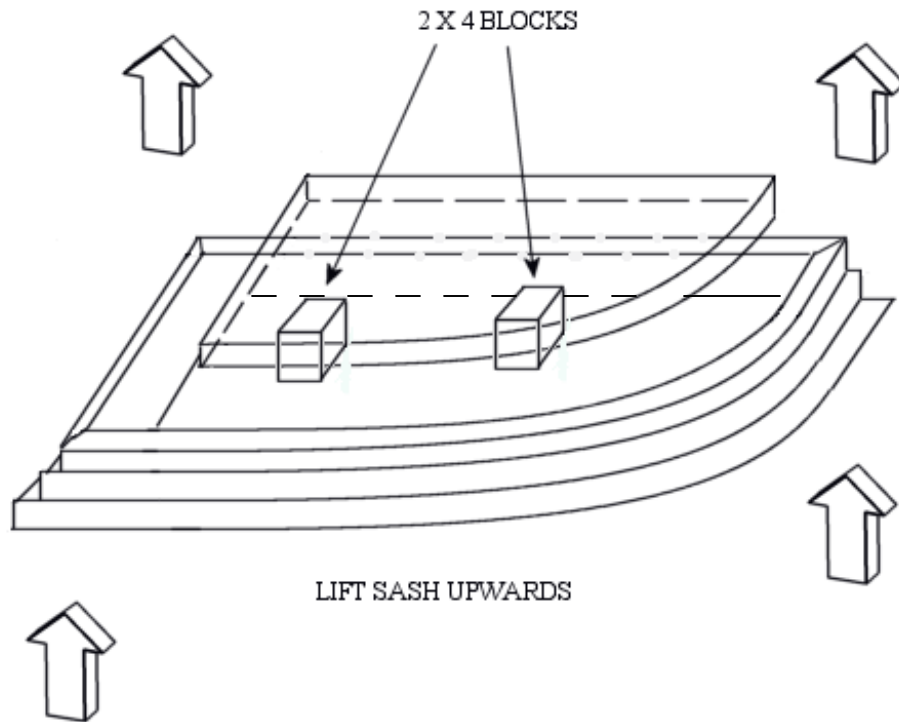

- ~ Replace the 3 pieces of bead in the reverse order they were removed; bottom, long back leg, then bent side. It's best to replace the bent leg starting at the top. A soft-blow mallet may be used.
- ~ Reapply PVC window cement, at the corners of the bead, where it was cut earlier.
- ~ Slide sash back into operator track and replace sash pins.